

Appendix D – Aerial Ignition Equipment Modifications

The following documents will be available for download at the BLM National Aviation Office website at: <http://www.blm.gov/nifc/st/en/prog/fire/Aviation/Airops/iaig.html>

- BLM Instruction Memorandum on Aerial and Ground Ignition Equipment Direction
- USFS Memo on Required Safety Modifications: Batch Mixer, Terratorch, Mix Transfer System, and Helitorch
- Northern (Canadian) Barrel Helitorch Required Safety Modifications
- Premo Mark III Modifications
- Aerostat Mark V PSD Approval Letter
- Helicopter Operations Harness Tether & Tether Attachment Drawing. MTDC-993

UNITED STATES DEPARTMENT OF THE INTERIOR
BUREAU OF LAND MANAGEMENT
Office of Fire and Aviation
3833 South Development Avenue
Boise, Idaho 83705

December 9, 2002

In Reply Refer To:
9210/9214 (FA-320) N

EMS Transmission 12/09/02
Instruction Memorandum No. OF&A 2003-007
Expires: 09/30/04

To: State Directors

From: Director, Office of Fire and Aviation
(Attn: Fire Management Officers and Fuels Management Specialists)

Subject: Aerial and Ground Ignition Equipment Direction

Program Area: Fire Management/Prescribed Fire Operations

Purpose: This Instruction Memorandum (IM) provides direction for bringing existing Bureau of Land Management (BLM) equipment into compliance with applicable regulations and nationally recognized standards. It also provides direction on procurement of new equipment.

Policy/Action:

1. Aerial and ground ignition equipment that has undergone all corrective actions identified in Attachment #1, "Corrective Actions for Aerial and Ground Ignition Equipment," may be put back into service. The following URL is a hotlink to a Power Point presentation with photos of aerial and ground ignition equipment features requiring corrective action:
<http://web.blm.gov/internal/fire/drctv.htm>
2. Field Offices must receive a written certification from the prescribed fire equipment manufacturers that their equipment includes all corrective actions identified in Attachment #1 prior to issuing a purchase order for that equipment.

3. A Job Hazard Analysis (JHA) will be completed prior to initiation of prescribed fire operations using this equipment. For additional guidance on the use of the JHA please refer to BLM Manual Handbook 1112-2, Topic 1, Job Hazard Analysis, and BLM Prescribed Fire Management Guidance, IM No. OF&A 2002-027, June 6, 2002.

Time Frame: This IM is effective upon receipt.

Budget Impact: Budget impact will vary depending on the age and condition of the equipment requiring corrective action. To determine best value, the field is encouraged to evaluate the cost of corrective action versus the purchase of new equipment that fully complies with the requirements of this IM.

Background: IM No. OF&A 2002-022, May 28, 2002, issued the Hazard Assessment and Proposed Resolution for Combination Gelled-Fuel Batch Mixer/Terratorch and Drip Fuel Transportation report and placed a moratorium on the use of existing batch mixing and terratorch equipment.

Interim direction for modification and resumed use of mix transfer systems was provided in IM No. OF&A 2002-031, June 27, 2002. This current IM supercedes IM No. OF&A 2002-031 and provides additional modifications that must be made prior to use of that equipment.

A follow-up technical evaluation of aerial and ground ignition equipment was conducted at the National Interagency Fire Center (NIFC) on October 16 – 18, 2002. The evaluation was conducted by an industry safety consultant, who serves as a member of the National Fire Protection Association (NFPA) Technical Committee that is responsible for NFPA Standard 385, Tank Vehicles for Flammable and Combustible Liquids. A list of corrective actions (Attachment #1) was developed to be implemented immediately. The safety consultant will provide a final report by January 24, 2003. This final report, along with the original hazard assessment, will serve as the basis for development of plans and specifications for the next generation of aerial and ground ignition equipment.

Manual/Handbook Sections Affected: No Manual/Handbook Sections are affected.

Coordination: Personnel from the BLM Compliance Assessment – Safety, Health, the Environment (CASHE) Program, the USDA Forest Service Missoula Technology and Development Center, and the safety consultant developed the corrective actions in Attachment #1. Input and information for the corrective actions was supplied by technical and operational specialists representing the National Wildfire Coordinating Group (NWCG), Aerial Ignition Working Team, San Dimas Technology and Development Center, the BLM Office of Fire and Aviation (Fire Operations, Aviation, and Planning and Resources), the Fish and Wildlife Service, the Forest Service, the Bureau of Indian Affairs, aerial and ground ignition equipment manufacturers, and a Private Contractor.

Contact: If you have any questions concerning this memorandum please contact Rick Jensen at (208) 387-5710.

Signed by:
Lynn P. Findley
Acting Director
Office of Fire and Aviation

Authenticated by:
Pat Lewis
Supervisory Mgmt. Asst.
Office Services

Distribution:

Anne Jeffery, FA-101, WO
Jay Thietten, FA-101, WO
WO-560
BLM ADs
BC Library
Group Manager, Fire Operations
Group Manager, Planning and Resources
Group Manager, Aviation
Group Manager, Support Services
Cyndie Hogg, NARTC
State FMOs

Attachment 1**Corrective Actions for Aerial and Ground Ignition Equipment****Fire Spec Systems: Spec 2000 Modular Transfer/Mixer**

These retrofits will be accomplished by the field in coordination with Joe Rawitzer, Fire Spec Systems, (831) 455-2498

1. Provide bonding lug on each drum's dry break fitting. Test for continuity after installation. Drums to be bonded to each other and the fuel truck.
2. Install spark arrester on muffler.
3. Eliminate kink on bypass hose and modify shield if necessary to fully shield the hose from the engine.
4. Install shield separating fuel piping and pump from internal combustion engine, if not already provided.
5. Remove collar around the internal combustion engine's fuel tank.
6. Mount Clay and Bailey relief vents on cam locks to keep them out of the gel. Note: relief vents must be in place prior to use of equipment.
7. Secure levers on cam lock caps together with safety pin to prevent them from opening accidentally.
8. Label drum inlets, outlets, and valves as to their appropriate function. In addition, flow direction through valves to be labeled. Labels to be engraved plastic or metal.
9. Isolate pressure gauge from fuel to prevent gelled-fuel from clogging gauge. Source for Compliant Gage: **Noshok**, Pressure Range: 0 PSI to 150 PSI Diameter: 2-1/8 to 2-1/4 inch, Special Equipment: equipped with sealed diaphragm, 316 SS - Stainless Steel: filled with GY liquid, Style: Type 25. Noshok, 1010 W. Bagley Rd., Berea, OH 44017, (440) 243-0888.

Fire Spec Systems: Spec 2000 Helitorch

These retrofits will be accomplished by the field in coordination with Joe Rawitzer, Fire Spec Systems (831) 455-2498

1. Mount Clay and Bailey relief vents on cam locks to keep them out of the gel. Note: relief vents must be in place prior to use of equipment.
2. Secure levers on cam lock caps together with safety pin to prevent them from opening accidentally.
3. Replace clip pin on containment band securing the drum to the helitorch frame with a safety pin.
4. Install aviation grade bolts and nuts on all attachments.
5. Protect bolts in sleeves where they are subject to wear on the pear-link adapter.
6. Prevent the threaded portion of the bolts from becoming a load-bearing surface.
7. Improve access to the ignition and pump control box by mounting it so the door opens toward the torch not the drum.
8. Modify gelled-fuel piping and associated supports to prevent the discharge end or tip of the piping from hitting the ground during landing or takeoff. Modification must not result in the installation of loose parts that can be lost.

9. Secure electrodes so they cannot be accidentally knocked out of adjustment, but are still easy to adjust.
10. All hardware (e.g., nuts, bolts, cargo hook attachment ring, etc.) to meet MTDC specification for helitorch suspension system. For drawings and specifications regarding helitorch and suspension system assembly and suspension cable and adapter, separator bar, helitorch please contact Missoula Technology and Development Center at (406) 329-3957.
11. Inspect wire rope slings for broken strands, kinking, or other physical damage and replace as necessary.

Firecon: Portable Mix-Transfer System

These retrofits will be accomplished by the field in coordination with Gene Jones, Firecon (541) 889-8630.

1. Provide bonding lug on each drum's dry break fitting. Test for continuity after installation. Drums to be bonded to each other and the fuel truck.
2. Replace nonconductive plastic funnel with metal funnel.
3. Secure levers on cam lock caps together with safety pin to prevent them from opening accidentally.
4. Label all valves permanently as to their function and direction of flow.
5. Isolate pressure gauge from fuel to prevent gelled-fuel from clogging gauge. Source for Compliant Gage: **Noshok**, Pressure Range: 0 PSI to 150 PSI Diameter: 2-1/8 to 2-1/4 inch, Special Equipment: equipped with sealed diaphragm, 316 SS - Stainless Steel: filled with GY liquid, Style: Type 25. Noshok, 1010 W. Bagley Rd., Berea, OH 44017, (440) 243-0888.
6. Install shield separating fuel piping and pump from internal combustion engine, if not already provided.

Firecon: Batch Mixer

These retrofits will be accomplished by Gene Jones, Firecon (541) 889-8630. A first article inspection will be conducted by Robert Stroud, Equipment Development Group, NIFC. Field Offices must call Gene Jones to schedule work to be done.

1. Bolt or weld cargo tank to trailer frame, not its expanded metal decking.
2. Seal permanently, all electrical connections, including live reel connections, and install protective covers over switch housings and the live reel wiring junction.
3. Install bronze gear pump with viton seals replacing cast iron pump.
4. Relocate fuel tank allowing it to be filled more easily and without spillage.
5. Install solid metal shield across the back of the engine/pump compartment.
6. Install solid metal shield in engine/pump compartment separating gelled-fuel piping and pump from belts and engine.
7. Remove expanded metal guard on engine side of the compartment.
8. Relocate fire extinguisher to front of trailer.
9. Extend emergency shut-off lever making it more accessible and provide detachable 20-foot lanyard.

10. Replace all hose and clamps with swedged conductive hose.
11. Replace bottom valve on batch mixer with larger valve to improve mixing, if this has not been accomplished already.
12. Replace supply hose to hose reel with hard pipe or swedged conductive hose. Pipe to be supported and secured. Swedged conductive hose to be protected from abrasion.
13. Protect all trailer wiring with split loom and secure it to the trailer frame. All wires passing through trailer frame to be protected from abrasion using rubber grommets.
14. Relocate battery to front of trailer and permanently mount. Run #4 cables in plastic conduit and secure to deck.
15. Secure levers on cam lock caps together with safety pin to prevent them from opening accidentally.
16. Label all valves permanently as to their function and direction of flow.
17. Install live reel to protect hose from abrasion and maintain internal bonding within hose.
18. Placard tank on all four sides using self-adhesive placards.

Firecon: Terratorch

These retrofits will be accomplished by Gene Jones, Firecon, (541) 889-8630. A first article inspection will be conducted by Robert Stroud, Equipment Development Group, NIFC

1. Bolt or weld torch skid to vehicle body.
2. Seal permanently all electrical connections and install protective cover over switch housings.
3. Install bronze gear pump with viton seals replacing cast iron pump.
4. Relocate fuel tank allowing it to be filled more easily and without spillage.
5. Install solid metal shield across the back of the engine/pump compartment.
6. Install solid metal shield in engine/pump compartment separating gelled-fuel piping and pump from belts and engine.
7. Remove expanded metal guard on engine side of the compartment.
8. Mount fire extinguisher independent from terratorch skid. This corrective action must be accomplished at the Field Office.
9. Extend emergency shut-off lever making it more accessible and provide detachable 20-foot lanyard.
10. Replace all hoses and clamps with swedged conductive hose.
11. Replace bottom valve on terratorch with larger valve to improve mixing, if this has not been accomplished already.
12. Protect all wiring on "after market" vehicle flat bed with split loom and secure it to the trailer frame. All wires passing through bed frame to be protected from abrasion using rubber grommets. Field Offices not sending the flat bed vehicle to be used with the terratorch must accomplish this corrective action at the Field Office.
13. Placard tank on all four sides using self-adhesive placards.
14. Relocate battery to front of vehicle bed or skid. Run #4 cables in plastic conduit and secure to vehicle bed or skid. A standard vehicle power cord and plug-in may also be used.
15. Secure levers on cam lock caps together with safety pin to prevent them from opening accidentally.

16. Label all valves permanently as to their function and direction of flow.
17. Install DOT specification cargo tank, minimum size 120-gallons.

Firecon: Terratorch Wand

These retrofits will be accomplished by the field in coordination with Gene Jones, Firecon, (541) 889-8630

1. Attach spring or universal swivel on hose where it connects to trigger assembly to prevent kinking.

Note: NIFC is developing a new wand that will have to be purchased when its development is completed.

Simplex: Helitorch

These retrofits will be accomplished by the field in coordination with Gene Jones, Firecon, (541) 889-8630 or Joe Rawitzer, Fire Spec Systems, (831) 455-2498. The DOT retrofit kit referenced in number 10 below can be obtained from Gene Jones or Joe Rawitzer.

1. Mount Clay and Bailey relief vents on cam locks to keep them out of the gel. Note: relief vents must be in place prior to use of equipment.
2. Secure levers on cam lock caps together with safety pin to prevent them from opening accidentally.
3. Install aviation grade bolts and nuts on all attachments.
4. Protect bolts in sleeves where they are subject to wear on the pear-link adapter.
5. Prevent the threaded portion of the bolts from becoming a load-bearing surface.
6. All hardware (e.g., nuts, bolts, cargo hook attachment ring, etc.) to meet MTDC specification for helitorch suspension system. For drawings and specifications regarding helitorch and suspension system assembly and suspension cable and adapter, separator bar, helitorch please contact Missoula Technology and Development Center at (406) 329-3957.
7. Inspect wire rope slings for broken strands, kinking, or other physical damage and replace as necessary.
8. Replace propane fuel line with double-walled metal braided propane line. New line to be routed without sharp bends and secured to prevent movement and abrasion.
9. Inspect power cord's outer insulation. Insulation to be continuous without cuts or gaps. Repairs to be made with insulating material equal to or great than the manufacturer's original outer insulation. Electrical tape is not acceptable.
10. Install DOT drum retrofit kit available from Firecon and Fire Spec Systems.

File Code: 5100

Date: January 6, 2003

Route To:

Subject: Required Safety Modifications: Batch Mixer, Terratorch, Mix Transfer System, and Helitorch

To: Regional Foresters, Station Directors, Area Director, IITF Director, Job Corps, and WO Staff

This letter provides guidance for required safety modifications to Forest Service batch mixers, terra torches, mix transfer systems, and helitorches. The *safety* modifications addressed in this letter and described in attachments must be accomplished no later than September 30, 2003. Each unit is responsible for the modification of their equipment.

The BLM commissioned a safety evaluation of its existing terra torches and batch mixers. As a result of this evaluation, the BLM terminated operations of its terra torches and batch mixers. The Forest Service chose not to take this action as a second evaluation was commissioned to resolve differences in interpretation of the NFPA codes. This evaluation was performed by a consultant who is a member of the NFPA technical committee on the transportation of flammable liquids. This committee is responsible for the preparation of NFPA 385, Standard for Tank Vehicles for Flammable and Combustible Liquids. As a result of this second evaluation, a list of modifications to improve the safety of gelled fuel mixing equipment and helitorches was developed. This work has included the involvement of MTDC specialists, Interagency Aerial Ignition Working Group members, and other Forest Service representatives from the initial phases.

In addition to the safety modifications required by this letter, the Missoula Technology and Development Center is currently working on modifications to enhance performance of existing batchmixers. Once these modifications have been developed and tested, a tech tip will be prepared outlining the suggested modifications. These *performance* modifications are not required but are intended to help field units improve the performance of equipment that is not working properly.

We will continue to work with BLM, other land management agencies, and the Aerial Ignition Working Group to develop improved standards, designs, and training for batch mixers, mix transfer systems, and helitorches that will address safety issues and performance issues identified by the field.

We also support efforts to formalize FEWT Firing Equipment Task Group to develop standards and training for ground firing equipment including terratorches, drip torches, flares, and other ignition devices.

Specific direction

- 1) Modify existing batch mixers and terra torches that have DOT 406 tanks per attachment 1.
- 2) Modify existing mix transfer systems per attachment 2.
- 3) Modify existing Fire Spec helitorches per attachment 3.
- 4) Modify existing Simplex helitorches per attachment 4.
- 5) Upgrade existing terra torches that are not DOT compliant to meet current DOT requirements or replace them with new DOT compliant equipment. All upgraded or new terratorches shall also include the modifications required in attachment 1.

New equipment may be ordered provided it includes the modifications required in attachments 1, 2, or 3.

If you have questions concerning policy, contact Neal Hitchcock at (208) 387-5949. For technical questions contact Wesley Throop at (406) 329-3957.

/s/ Tony Kern (for)
JERRY T. WILLIAMS
Director, Fire and Aviation Management

Attachment 1**Required Batchmixer and Terratorch Modifications**

For trailer-mounted units, the cargo tank must be bolted or welded to the trailer frame, not to the expanded metal decking. If necessary, supports may be welded to the trailer frame and the tank bolted or welded to these supports.

For skid-mounted units that are carried on a vehicle, the skid must be bolted or welded to the vehicle.

Permanently seal all electrical connections to prevent them from coming loose and sparking.

Install a protective cover over any switch housings to reduce sparking.

Replace the existing steel gear pump with a bronze gear pump with viton seals to eliminate potential sparking due to metal-to-metal contact.

Relocate the fuel tank of the gasoline engine that drives the pump as required to allow it to be more easily filled without spilling fuel on a hot engine.

Install a solid metal shield across the back of the engine/pump compartment to prevent leaks from piping or hoses from contacting a hot engine.

Modify the emergency shut-off lever as needed to provide ready access and provide a 20' lanyard to enable the tank to be shutoff in an emergency.

Install a solid metal shield in the pump/engine compartment between the pump and the engine to prevent gasoline from being sprayed on a hot engine in the event of piping leaks or pump seal failure.

Replace all hoses that have clamped end fittings with conductive hoses that have swedged end fittings to eliminate leakage points and insure electrical bonding throughout the system. Verify conductivity of the new hoses prior to installation.

Replace the supply hose to the batch mixer hose reel with hard pipe or swedged conductive hose to eliminate leakage points and insure electrical bonding throughout the system. If pipe is installed it must be supported and secured. If hose is installed it must be protected from abrasion.

Relocate the battery for the engine to the front of the trailer, vehicle bed, or terra torch skid and permanently mount it to reduce spark hazards near the pump and piping. Run #4 cables in plastic conduit and secure to the deck of the trailer.

Install split loom around all trailer or after market vehicle bed wiring and protect all wires passing through the trailer frame with grommets to prevent the wires from abrading on the frame and shorting out. Secure all wiring to the trailer.

Install safety pins on the cam lock cap levers to prevent them from opening during transportation.

Isolate the pressure gage from the gelled fuel to prevent the gel from clogging the gage.

Remove the expanded metal guard on the engine side of the compartment.

Permanently label all valves as to function and direction of flow.

Install a live reel on each batch mixer to protect the hose from abrasion and to maintain internal bonding within the hose.

Insure the tank is properly placarded on all four sides using self-adhesive placards.

Insure the fire extinguisher is permanently mounted near the front of the trailer or mounted independent of the terra torch skid.

Replace non-compliant tanks with DOT specification cargo tanks.

Install a spring or universal swivel on the terratorch wand hose where it connects to the trigger assembly to prevent kinking.

If the batch mixer or terratorch is trailer mounted, the trailer must be equipped with brakes if the gross trailer weight rating is 1500 lbs or more. The brake must be designed so the operator can activate them independently of the vehicle foot brakes. (FSH 7109.19,31.3)

Attachment 2**Required Mix Transfer System Modifications**

Install bonding lugs on each drum's dry break fittings to prevent static electricity discharge. Verify continuity. During operation the drums must be bonded to each other and the fuel truck.

Insure a relief valve is installed on each drum to prevent collapsing the drum when gelled fuel is pumped out and the vapor hose connection port has been accidentally left capped. Each relief valve must be mounted on a cam lock fitting to prevent gelled gasoline from clogging the valve.

Install safety pins on the cam lock cap levers to prevent them from opening when the system is being transported.

Install an approved spark arrestor on the muffler of the gasoline engine.

Eliminate kinks in the bypass hose.

Label all drum connections, and valves as to their appropriate function and flow direction with engraved metal or plastic labels.

Isolate the pressure gage from the gelled fuel to prevent the gel from clogging the gage.

Install a shield between the pump and gasoline engine to prevent gasoline from being sprayed on a hot engine in the event of piping leaks or pump seal failure.

Replace the non-conductive plastic funnel used to add gelling agent to the gasoline with a metal funnel to prevent static discharge.

Install guards as needed over all rotating shafts.

Attachment 3**Fire Spec Helitorch Modifications**

Insure the Clay and Bailey relief valve is installed. Mount the valve in a cam lock fitting to prevent it from being clogged by the gelled fuel.

Install safety pins on the cam lock cap levers to prevent them from opening when the helitorch is being transported.

Replace the clip pin on the drum containment band that secures the drum to the helitorch frame with a safety pin.

Replace standard grade bolts, nuts, and washers on helitorch suspension with aviation grade bolts, nuts, and washers (Parts 37, 38, 39, 40, 41, 42, and 44, Drawing MEDC-768).

Insure the spacer (Part 4, Drawing MEDC-768) is installed in the suspension adapter to prevent wear on the bolt from the pear link adapter.

Mount the ignition and pump electrical control box so that the door can be opened completely to allow access to the components inside.

Modify the fuel discharge piping so that the tip and electrodes do not hit the ground during take off and landing. This modification must not result in the installation of loose parts that can be lost.

Secure the electrodes so they cannot be accidentally knocked out of adjustment, but are still easy to adjust.

All suspension hardware to be per MTDC drawing MEDC-768.

Attachment 4**Simplex Helitorch Modifications**

Install retrofit kit to make fuel drum DOT compliant. This kit is available from Firecon or Fire Spec.

Insure the Clay and Bailey relief valve is installed. Mount the valve in a cam lock fitting to prevent it from being clogged by the gelled fuel.

Install safety pins on the cam lock cap levers to prevent them from opening when the helitorch is being transported.

Inspect the suspension system wire ropes for broken strands, kinking, or other physical damage. Replace any defective wire rope.

Insure the nuts, bolts, and washers on the helitorch suspension with aviation grade (Parts 37, 38, 39, 40, 41, 42, and 44, Drawing MEDC-768).

Insure the spacer (Part 4, Drawing MEDC-768) is installed in the suspension adapter to prevent wear on the bolt from the pear link adapter.

All suspension hardware to be per MTDC drawing MEDC-768.

Inspect the insulation on the power cord. The insulation shall not have any cuts or cracks. Repair or replace as necessary. Electrical tape is not acceptable for repairing the insulation.

Replace the propane fuel line with a double walled metal braided line. Route the new line so that it does not have any sharp bends and secure the line to prevent movement and abrasion.

Equipment Retrofit Options and Availability

Several vendors are currently working on equipment and procedures for retrofitting helitorches, batchmixers, and terratorches. Contact your Regional Helicopter Operations Specialist for these companies prior to retrofitting existing equipment or the purchase of new equipment.

The approximate costs for a complete retrofit kit for the Simplex model #5400 helitorch (including DOT barrel) is \$1,000.

Retrofit Kit (includes)

UN 1A2 type DOT barrel
 2-inch site glass (3)
 2-inch relief valve (Clay and Bailey)
 2-inch male Cam Lock fitting
 2-inch Cam Lock dust cover (Cap)
 Cable tie downs (barrel) with nuts
 Metal frame (adapter) with bolts

Accessories

Vapor removal/recovery hose
 2-inch female Cam Lock fitting
 2-inch Cam Lock dust plug
 Emco Wheaton 2-inch adapter
 Emco Wheaton 2-inch coupler
 Civacon 2-inch male adapter
 Civicon 2-inch coupler



Interagency Aerial Ignition Working Group (IAIG)

April 1, 2011

Mr. Shad Sitz
Interagency Helicopter Operations Steering Committee Chair
National Park Service, Pacific West Regional Office
Redmond, OR 97756

Mr. Sitz:

As the Chair of the Interagency Aerial Ignition Working Group, I am recommending the approval of the Canadian Northern Helitorch to be used as an aerial ignition device for wildland and prescribed fires. The torch is very similar to the T & T helitorch that was approved in 2009, in coordination with that approval and additional field testing the helitorch shall be approved with the following equipment changes:

1. MTDC single point suspension.
2. Propane regulator and hoses protected to avoid entanglement with the single point suspension system
3. Sealed switches and solenoid in a sealed control box, with guarded Ignition switches.
4. Stainless Steel Braided lines on all of the propane system.
5. From the pump to the tip of the torch be fitted with permanent fittings (swedges), no loose hose clamps.

It is our recommendation to the Interagency Helicopter Operations Steering Committee that the Canadian Northern Helitorch, be approved for purchase and use by all agencies using the Interagency Aerial Ignition Guide.

All members of the working group and sub group were polled for their views on approval of the Canadian Northern Helitorch. No negative responses were received.

If you have any further questions, additions, or comments, please do not hesitate to contact me.

Sincerely,

Jay Lusher
Interagency Aerial Ignition Working Group Chair
Grand Canyon National Park
928-606-3452

IHOPS APPROVED

Sent to NIAC 4-18-2011
Shad R.Sitz IHOps Interagency Helicopter
Operations Steering Committee

A handwritten signature in black ink, appearing to read "Shad R. Sitz".



Interagency Helicopter Operations Steering Committee (IHOps)

December 09, 2009

The Interagency Aerial Ignition Working Group requested approval of the following modifications of the Premo MK III by Premofire Canada Ltd:

- Hopper Agitation Plate
- Hopper to Feed Chute Attachment Pin
- New Exit Chute Design
- One Piece Stainless Steel Needles
- Needle Valve Lock Nuts
- Push Button Bleed Valve
- Flexible Tubing
- Manifold Cleanout Plugs
- Longer Belly Strap
- Belly Strap Attachment Points
- New Belly Strap Buckle
- Aluminum Storage and Transportation Box

The Premo Mark III was tested by MTDC and then used in the field with positive results. The purchase and use of this device will be included into the 2010 Interagency Aerial Ignition Guide. The IHOps Steering Committee along with NIAC has approved the purchase and use of the Premo MK III with modifications.

/s/ Vince Welbaum

Vince Welbaum
Chair, Interagency Helicopter Operations Steering Committee
(208) 387-5634 office
(208) 867-2613 cell
vwelbaum@fs.fed.us

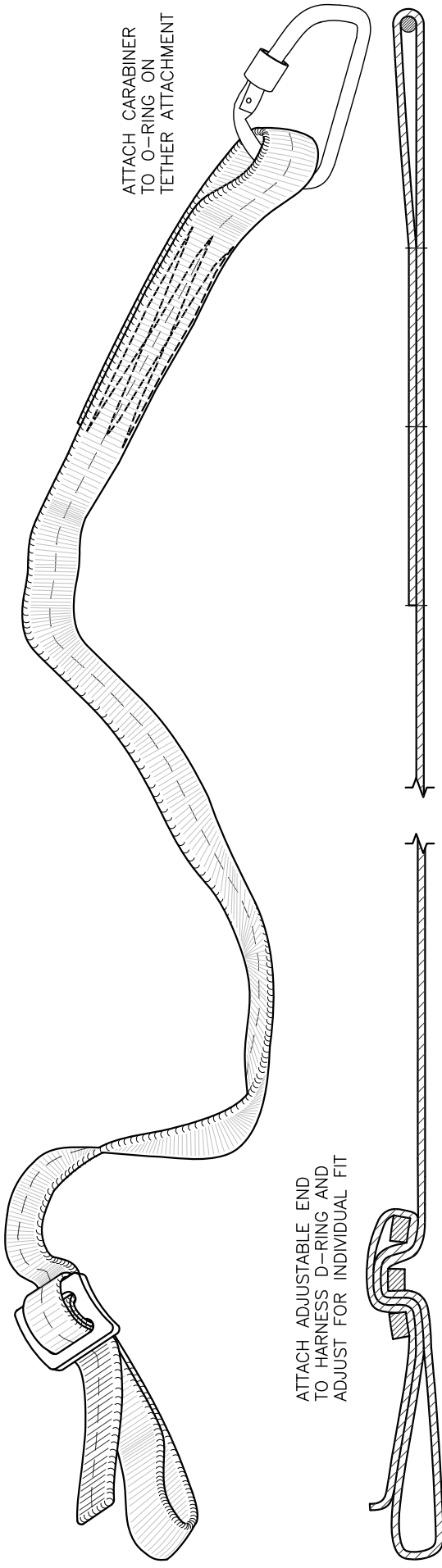

ATTACH CARABINER TO O-RING ON TETHER ATTACHMENT

ATTACH ADJUSTABLE END TO HARNESS D-RING AND ADJUST FOR INDIVIDUAL FIT

TAG END OF WEBBING PASSED THROUGH BUCKLE AGAIN TO ENSURE A SECURE HOLD



DETAIL A

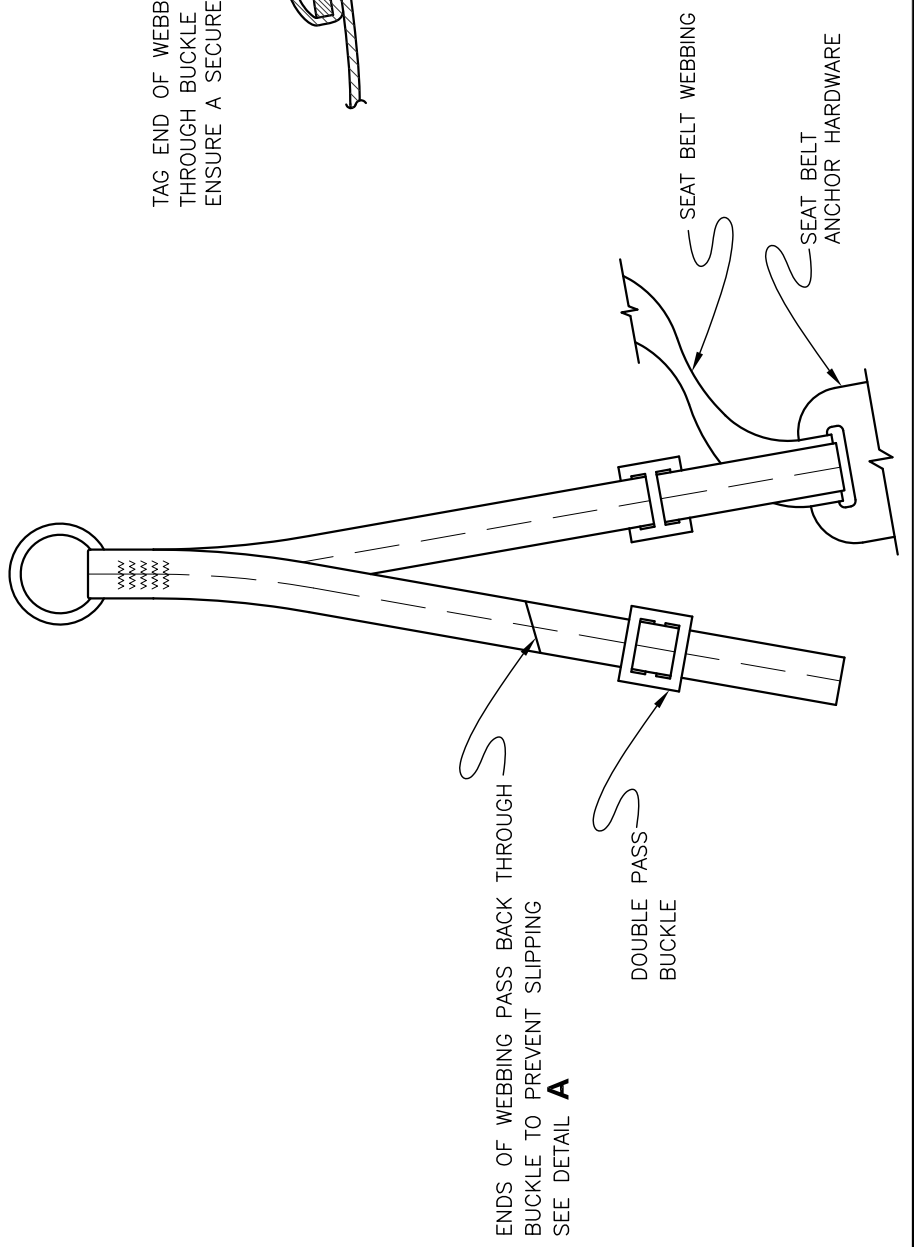

ENDS OF WEBBING PASS BACK THROUGH BUCKLE TO PREVENT SLIPPING SEE **DETAIL A**

DOUBLE PASS BUCKLE

SEAT BELT WEBBING

SEAT BELT ANCHOR HARDWARE

UNLESS OTHERWISE SPECIFIED:		DATE	REVISION	DWM	BY
TOLERANCES:	FRACTIONS +/-				
	DECIMALS +/-				
	ANGLES +/-				
DIMENSIONS ARE IN INCHES BREAK SHARP EDGES					
DRAWN	MUCCI				
DESIGNED	JACKSON				
CHECKED	JACKSON				
APPROVED	JACKSON				
SCALE	NONE				
DATE	FEB 2002				
TITLE				SHEET 1 OF 1	
U. S. DEPT. OF AGRICULTURE FOREST SERVICE TECHNOLOGY & DEVELOPMENT CENTER MISSOULA, MONTANA				MTDC- 993	
HELICOPTER OPERATIONS HARNESS TETHER & TETHER ATTACHMENT				MTDC- 993	